

1. Mechanical Dimensions:

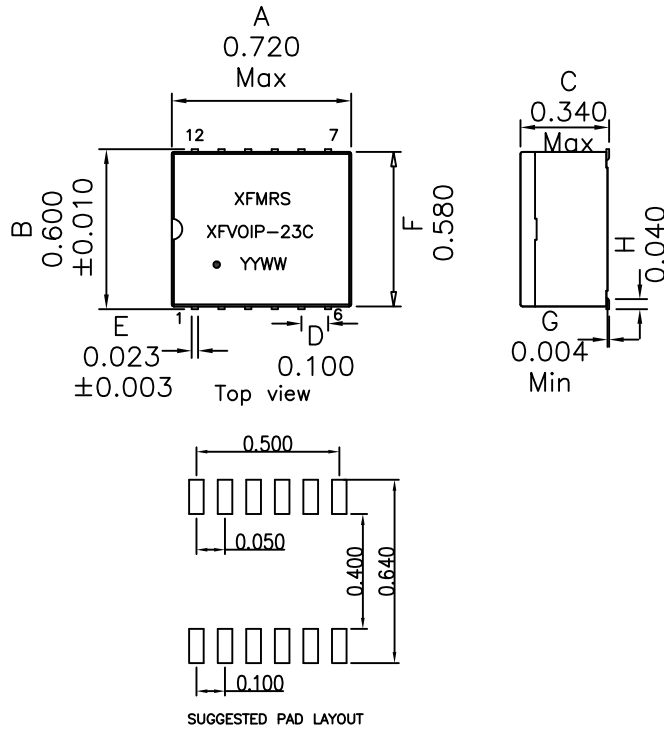

2. Schematic:

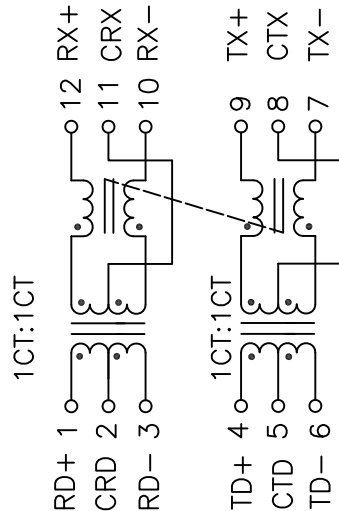

3. Electrical Specifications: @25°C

HIPOT: 1800Vrms 1Sec (tie 1+4, 12+9)

OCL: Pins 12-10 350uH Min @100KHz 0.1V 24mAdc

OCL: Pins 9-7 350uH Min @100KHz 0.1V 24mAdc

Q: 5.00 Min @10KHz 50mV

Turns Ratio: (1-3):(12-10)=1CT:1CT±2%

(4-6):(9-7)=1CT:1CT±2%

Insertion Loss:

@500KHz-100MHz -1.0dB Max

Return Loss:

@500KHz-30MHz -18dB Typ

@30-45MHz -15dB Typ

@45-60MHz -13dB Typ

@60-80MHz -12dB Typ

Crosstalk: @1-100MHz -35dB Min

DCMR: @1-30MHz -43dB Min

@30-60MHz -37dB Min

@60-100MHz -33dB Min

Designed to handle 720mADC and meet 802.3at

Notes:

- Solderability: Leads shall meet MIL-STD-202G, Method 208H for solderability.
- Flammability: UL94V-0
- ASTM oxygen index: > 28%
- Insulation System: Class F 155°C. UL file E151556
- All listed parameters are to be within tolerance from 0°C to +70°C unless otherwise noted.
- Storage Temperature Range: -55°C to +125°C
- Aqueous wash compatible
- SMD Lead Coplanarity: ±0.004"(0.102mm)
- Electrical and mechanical specifications 100% tested
- RoHS Compliant Component

XFMRs Inc. www.XFMRs.com	Title: PoE+ Xfmr		
	UNLESS OTHERWISE SPECIFIED TOLERANCES: .xxx ±0.010 Dimensions in Inch		P/N: XFVOIP-23C REV. A
SHEET 1 OF 1	DWN.	Xiang	Mar-28-16
	CHK.	YK Liao	Mar-28-16
	APP.	BSJ	Mar-28-16

DOC. REV: A/2

PROPRIETARY

Document is the property of XFMRs Group & is not allowed to be duplicated without authorization.