

1. Mechanical Dimensions:

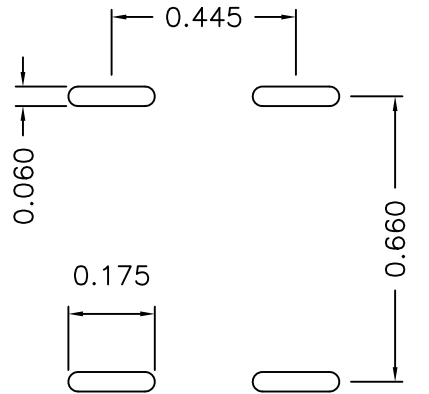
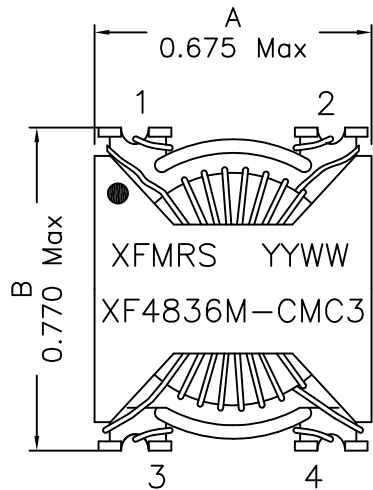
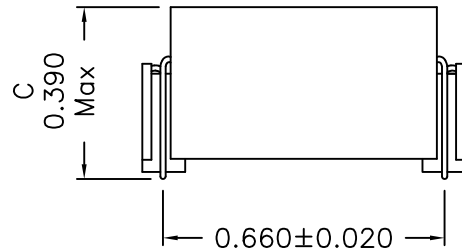
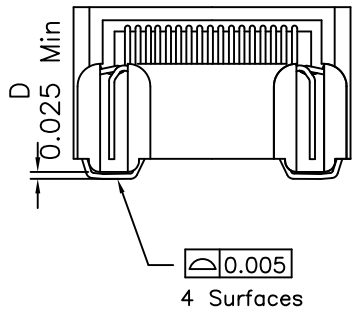

(SUGGESTED MOUNTING PAD)

Notes:

1. Solderability: Leads shall meet MIL-STD-202G, Method 208H for solderability.
2. Flammability: UL94V-0
3. ASTM oxygen index: > 28%
4. Insulation System: Class F 155°C. UL file E151556
5. All listed parameters are to be within tolerance from -40°C to +130°C unless otherwise noted.
6. Storage Temperature Range: -55°C to +125°C
7. Aqueous wash compatible
8. SMD Lead Coplanarity: ±0.004"(0.102mm)
9. Electrical and mechanical specifications 100% tested
10. RoHS Compliant Component
11. Recommended IR Reflow peak temp of 250C Max.

2. Schematic:

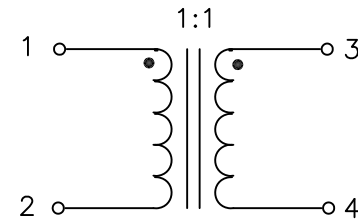

3. Electrical Specification: @25°C

- OCL: 483.7uH+30%/-35% @20KHz,10mV Each Wdg
 185uH Min @20KHz,10mV Each Wdg -40°C to 130°C
- Q: 15 Min @20KHz 10mV
- LL: 1-2 1.50uH Min @100KHz, 10mV (Short 3-4)
- DCR: 1-2 7.0mOhms (Typ), 7.70mOhms (Max)
- DCR: 3-4 7.0mOhms (Typ), 7.70mOhms (Max)
- Turn Ratio: (1-2):(3-4) = 1.00:1.00±2%
- Rated Current: 8A
- Hipot: (1-2) to (3-4) 1500Vac

DOC. REV: A/3

XFMRS Inc. www.XFMRS.com	Title: Common Mode Choke		
	UNLESS OTHERWISE SPECIFIED TOLERANCES: .xxx ±0.010 Dimensions in Inch		P/N: XF4836M-CMC3
SHEET 1 OF 2	DWN.	Yuan	Aug-07-15
	CHK.	YK Liao	Aug-07-15
	APP.	DDC	Aug-07-15

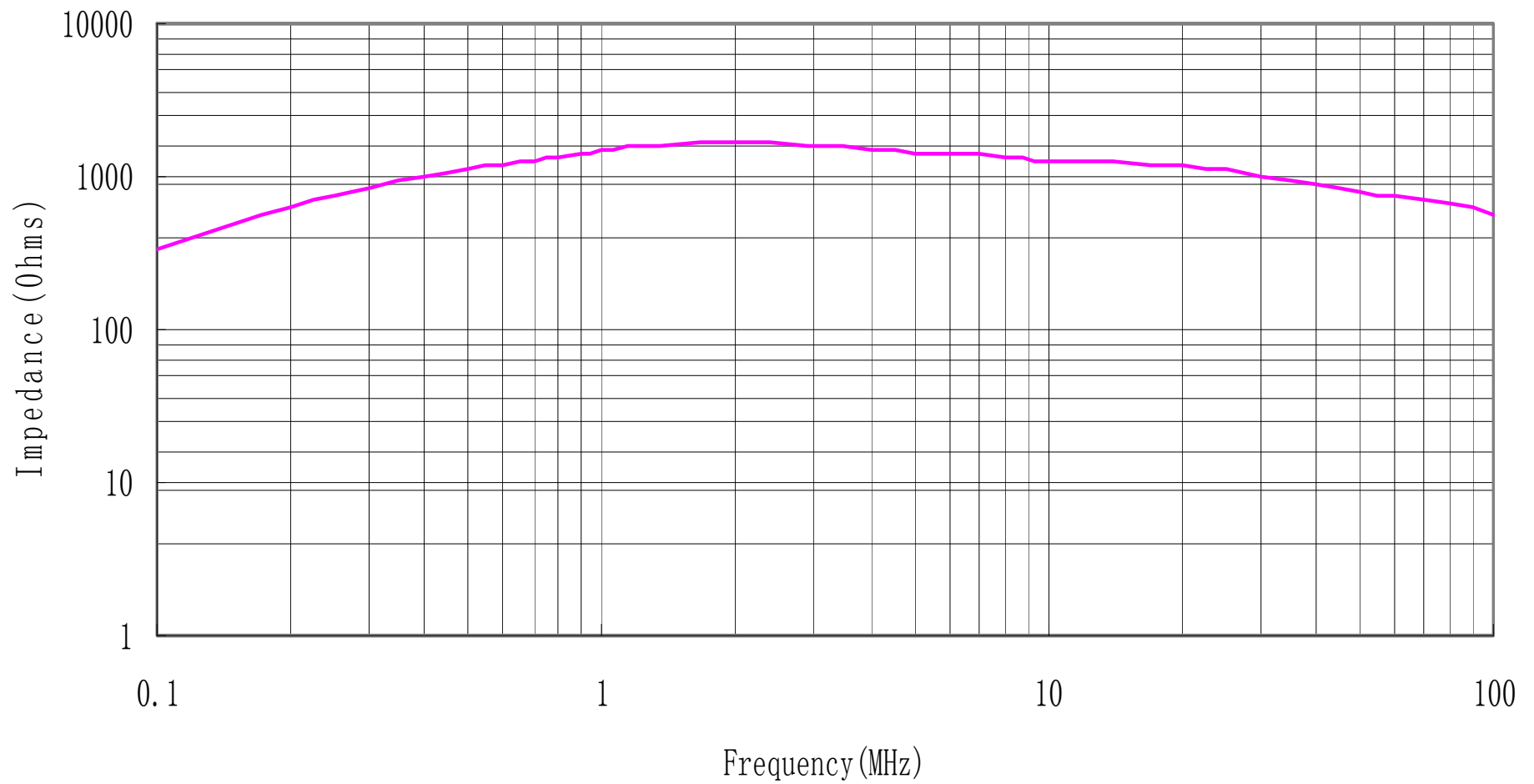

DOC. REV: A/3

XFMRs Inc. www.XFMRS.com	Title: Common Mode Choke		
	UNLESS OTHERWISE SPECIFIED TOLERANCES: .xxx ±0.010 Dimensions in Inch		P/N: XF4836M-CMC3 REV. A
SHEET 2 OF 2	DWN.	Yuan	Aug-07-15
	CHK.	YK Liao	Aug-07-15
	APP.	DDC	Aug-07-15

PROPRIETARY

Document is the property of XFMRs Group & is not allowed to be duplicated without authorization.