

## 1. Mechanical Dimensions:

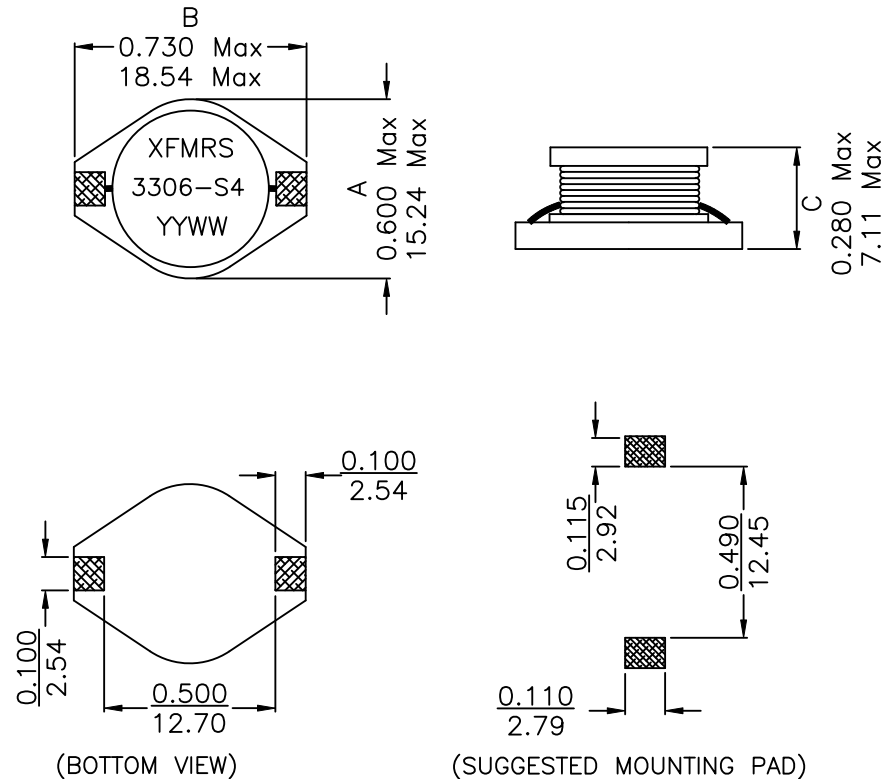

## 2. Schematic:

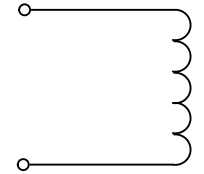

## 3. Electrical Specifications: @25°C

OCL: 330uH±20% @100KHz 0.1V

Q: 8 Min @100KHz 0.1V

DCR: 0.560 Ohms Max

I<sub>sat</sub>: 1.7 A (Based on 10% Typ drop in OCL)

1.9 A (Based on 20% Typ drop in OCL)

I<sub>rms</sub>: 1.0 A

SRF: 4.00 MHz Typ

### Notes:

1. Solderability: Leads shall meet MIL-STD-202G, Method 208H for solderability.
2. Flammability: UL94V-0
3. ASTM oxygen index: > 28%
4. Insulation System: Class F 155°C. UL file E151556
5. Operating Temperature Range: -40°C to +85°C
6. Storage Temperature Range: -55°C to +125°C
7. Aqueous wash compatible
8. SMD Lead Coplanarity: ±0.004"(0.102mm)
9. Electrical and mechanical specifications 100% tested
10. RoHS Compliant Component
11. Recommended IR Reflow peak temp of 260°C Max.

DCO. REV. A/5

<b>XFMRs®</b> <a href="http://www.XFMRS.com">www.XFMRS.com</a>	Title: <b>XF3306-S4 SERIES INDUCTORS</b>		
	P/N: XF3306-S4	REV. A	
UNLESS OTHERWISE SPECIFIED TOLERANCES: .xxx ±0.010 INCH Dimensions in INCH/MM	DWN.	Yu	Jul-25-20
	CHK.	YK Liao	Jul-25-20
SHEET 1 OF 1	APP.	BSJ	Jul-25-20

# XFMRs®

## Recommended Infrared Reflow Temperature Profile for RoHS Compliant Parts

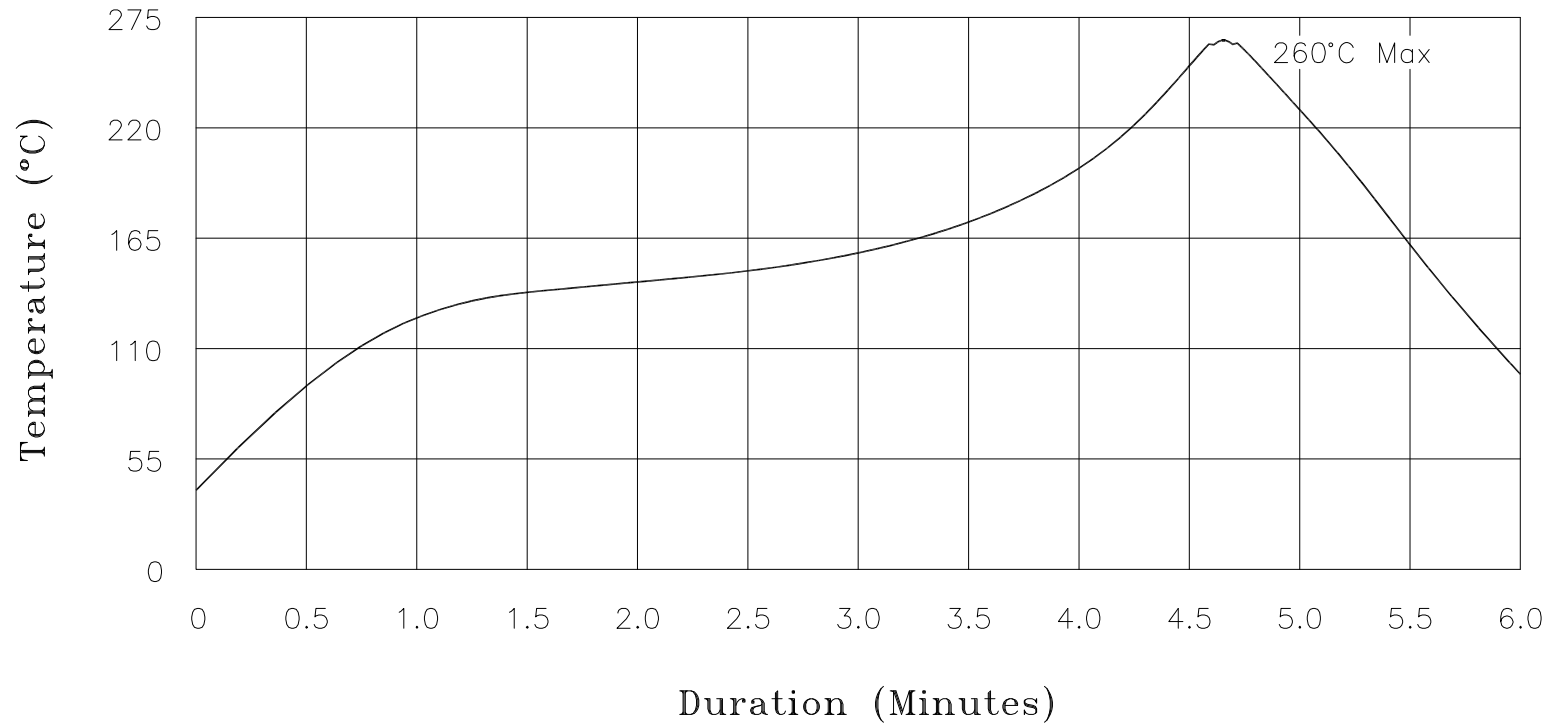

NOTES: Maximum duration at 260°+0/-5° with 10 seconds Max.  
 Maximum duration above 217° shall be 60-150 seconds.  
 ALL Temperatures refer to topside of the package, measured on the package body surface.

<b>XFMRs®</b> www.XFMRs.com	Title: <b>IR REFLOW CHART</b> (RoHS Compliant parts)		
	UNLESS OTHERWISE SPECIFIED TOLERANCES: N/A	P/N: N/A	REV. A
SHEET 1 OF 1	DWN.	Juan Mao	Jan-16-05
	CHK.	YK Liao	Jan-16-05
	APP.	MS	Jan-16-05

# TAPE AND REEL SPECIFICATION:

## NOTES:

- 1) PROCESS IN ACCORDANCE WITH EIA-481-2 STANDARDS
  - \* TAPE LEADER DIMENSION 15.30" MIN.
  - \* TAPE TRAILER DIMENSION 6.30" MIN.
- 2) PARTS SHOULD BE PACKAGED IN ACCORDANCE WITH ESD GUIDELINES IN EIA-541.
- 3) REEL LABEL: 'A' \* PART NUMBER
  - \* QUANTITY
  - \* DATE CODE
- 'B' - ANTI-STATIC CAUTION LABEL
- 4) 320PCS PER 13" REEL

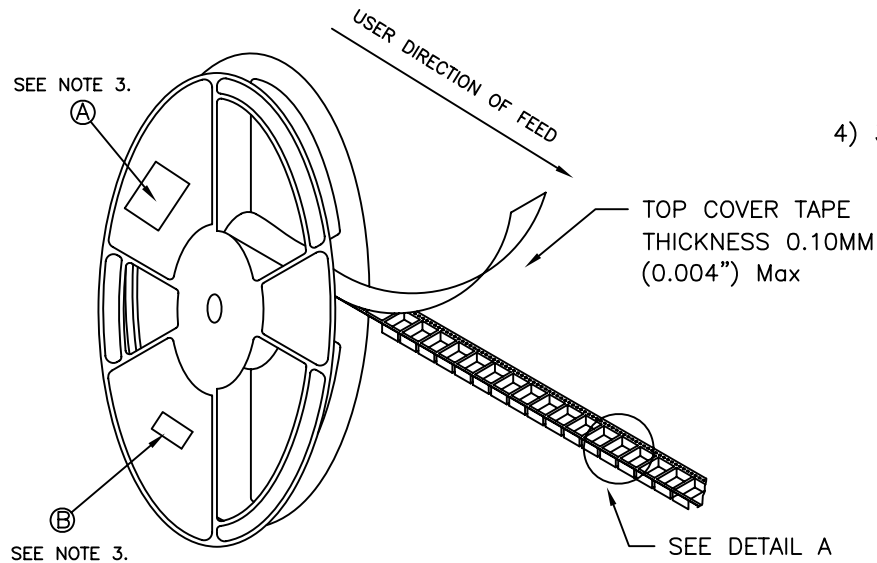

REEL AND TAPE ORIENTATION

**13" REEL DIAMETER**

DETAIL A

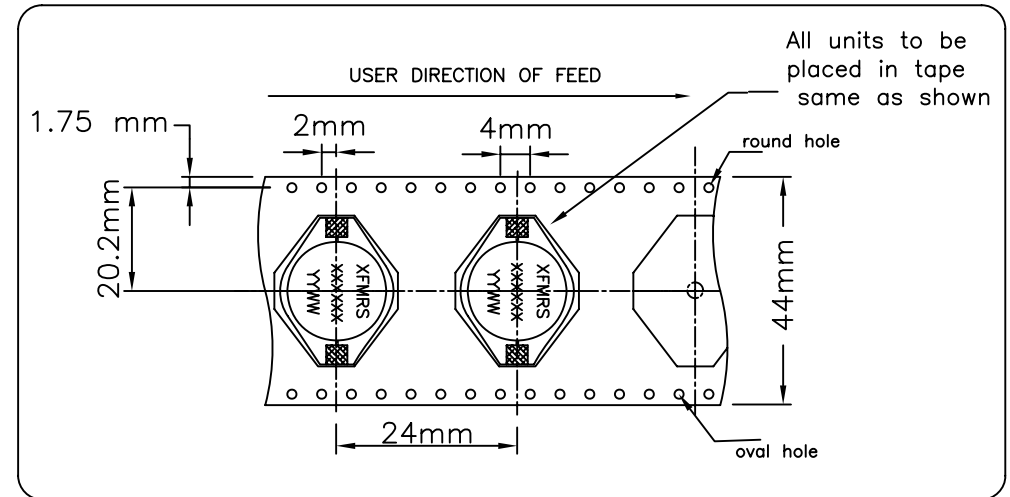

DOC REV:A/1

<b>XFMRS Inc</b>	Title: T&R SPEC		
	UNLESS OTHERWISE SPECIFIED TOLERANCES:		P/N: SMD4 SERIES
	.xxs ±xxxxx		REV: A
	Dimensions in mm		DWN. RP CHEN AUG-25-03
		CHK. WENG AUG-25-03	
		APP. BW AUG-25-03	