

## 1. Mechanical Dimensions:

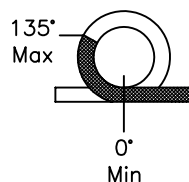

Strip Length

## 2. Schematic:

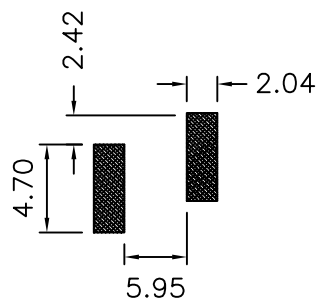
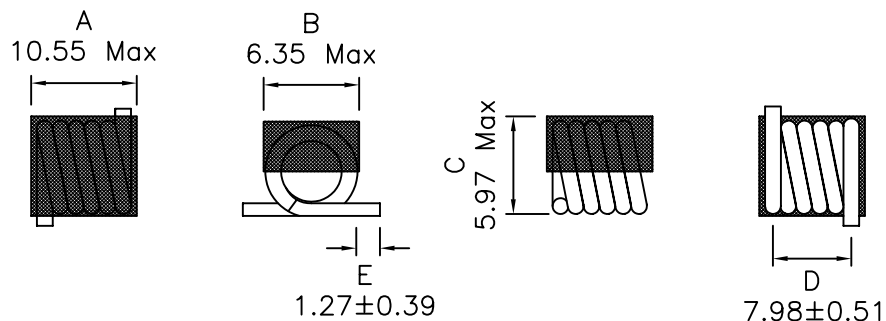
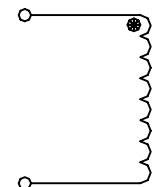

## 3. Electrical Specifications:

OCL: 246nH±5%

Q: 95 Min

TEST FREQ: 50MHz

SRF: 685MHz Min

DCR: 35 mOhms Max

IDC: 3.0A Max

### Notes:

1. Solderability: Leads shall meet MIL-STD-202G, Method 208H for solderability.
2. Flammability: UL94V-0
3. ASTM oxygen index: > 28%
4. Insulation System: Class F 155°C. UL file E151556
5. Operating Temperature Range: All listed parameters are to be within tolerance from -40°C to +125°C
6. Storage Temperature Range: -55°C to +125°C
7. Aqueous wash compatible
8. SMD Lead Coplanarity: ±0.004"(0.102mm)
9. Electrical and mechanical specifications 100% tested
10. RoHS Compliant Component

DOC. REV: A/1

<b>XFMRs Inc.</b> www.XFMRS.com		Title: Micro Spring Air Core Inductors		
UNLESS OTHERWISE SPECIFIED TOLERANCES: .xx ±0.25 Dimensions in MM	P/N: XF132-15SMJ		REV. A	
	DWN.	Feng	Feb-17-12	
SHEET 1 OF 1	CHK.	YK Liao	Feb-17-12	
	APP.	BW	Feb-17-12	

**PROPRIETARY**

Document is the property of XFMRs Group & is not allowed to be duplicated without authorization.