

1. Mechanical Dimensions:

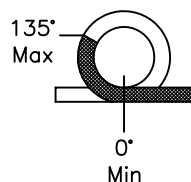

Strip Length

2. Schematic:

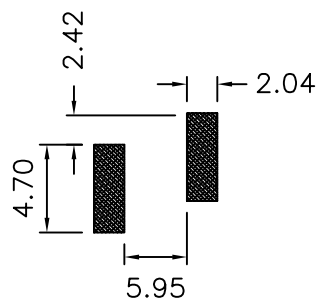
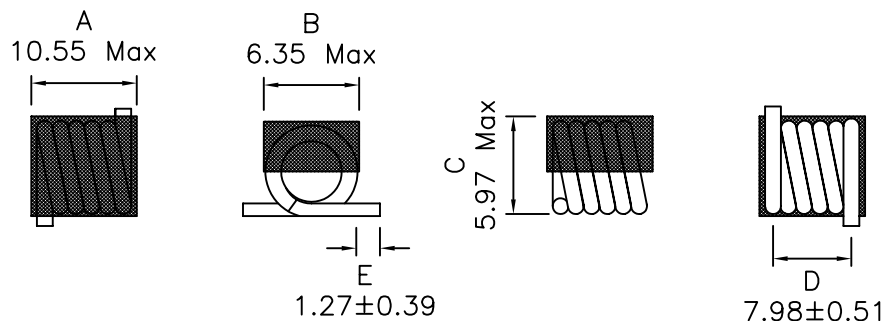
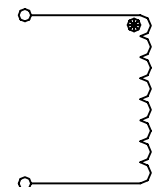

3. Electrical Specifications:

OCL: 90nH±5%

Q: 95 Min

TEST FREQ: 50MHz

SRF: 1140MHz Min

DCR: 15.0 mOhms Max

IDC: 3.5A Max

Notes:

- Solderability: Leads shall meet MIL-STD-202G, Method 208H for solderability.
- Flammability: UL94V-0
- ASTM oxygen index: > 28%
- Insulation System: Class F 155°C. UL file E151556
- Operating Temperature Range: All listed parameters are to be within tolerance from -40°C to +125°C
- Storage Temperature Range: -55°C to +125°C
- Aqueous wash compatible
- SMD Lead Coplanarity: ±0.004"(0.102mm)
- Electrical and mechanical specifications 100% tested
- RoHS Compliant Component

DOC. REV: A/1

XFMRs Inc. www.XFMRS.com		Title: Micro Spring Air Core Inductors		
UNLESS OTHERWISE SPECIFIED TOLERANCES: .xx ±0.25 Dimensions in MM	P/N: XF132-09SMJ		REV. A	
	DWN.	Feng	Feb-17-12	
SHEET 1 OF 1	CHK.	YK Liao	Feb-17-12	
	APP.	BW	Feb-17-12	

PROPRIETARY

Document is the property of XFMRs Group & is not allowed to be duplicated without authorization.