

1. Dimensions:

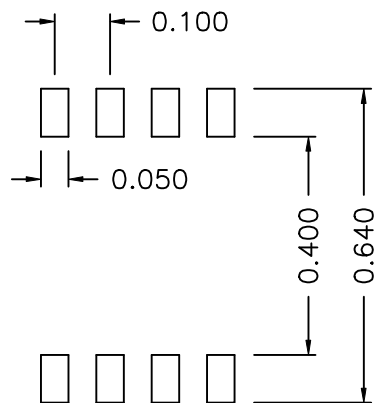

SUGGESTED FOOTPRINT

2. Schematic:

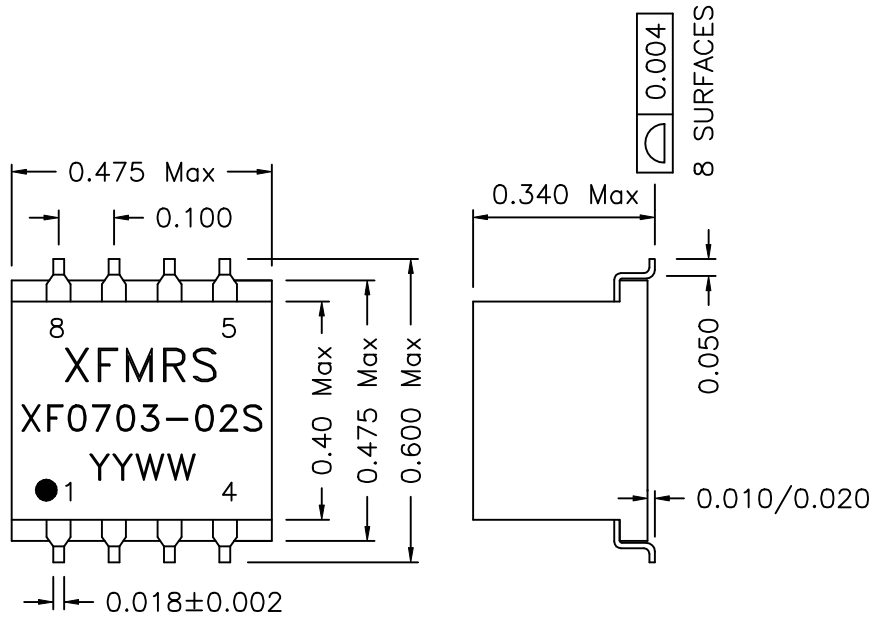
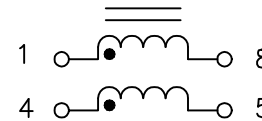

3. Electrical Specifications: @25°C

Isolation Voltage: 500Vrms

Turns Ratio: 1:1±2%

OCL: 70mH+50-30% @10KHz, 0.1V Each Wdg.

LL: 1-8, 350nH Max @100KHz, 0.1V Short all other Wdgs.

DCR: 0.660 Ohms Typ Each Wdg.

Rated Current: 300mAac

Notes:

1. Solderability: Leads shall meet MIL-STD-202, Method 208D for solderability.
2. Flammability: UL94V-0
3. ASTM oxygen index: > 28%
4. Insulation System: Class F 155°C. UL file E151556
5. Operating Temperature Range: All listed parameters are to be within tolerance from -40°C to +85°C
6. Storage Temperature Range: -55°C to +125°C
7. Aqueous wash compatible

XFMRS Inc	Title: COMMON MODE CHOKE		
	UNLESS OTHERWISE SPECIFIED TOLERANCES: .xxx ±0.010 Dimensions in Inch	P/N: XF0703-02S	REV. A
	DWN.	李清儿	Mar-20-03
	CHK.	孙悦	Mar-20-03
	APP.	BW	Mar-20-03

DOC. REV A/1