

1. Mechanical Dimensions:

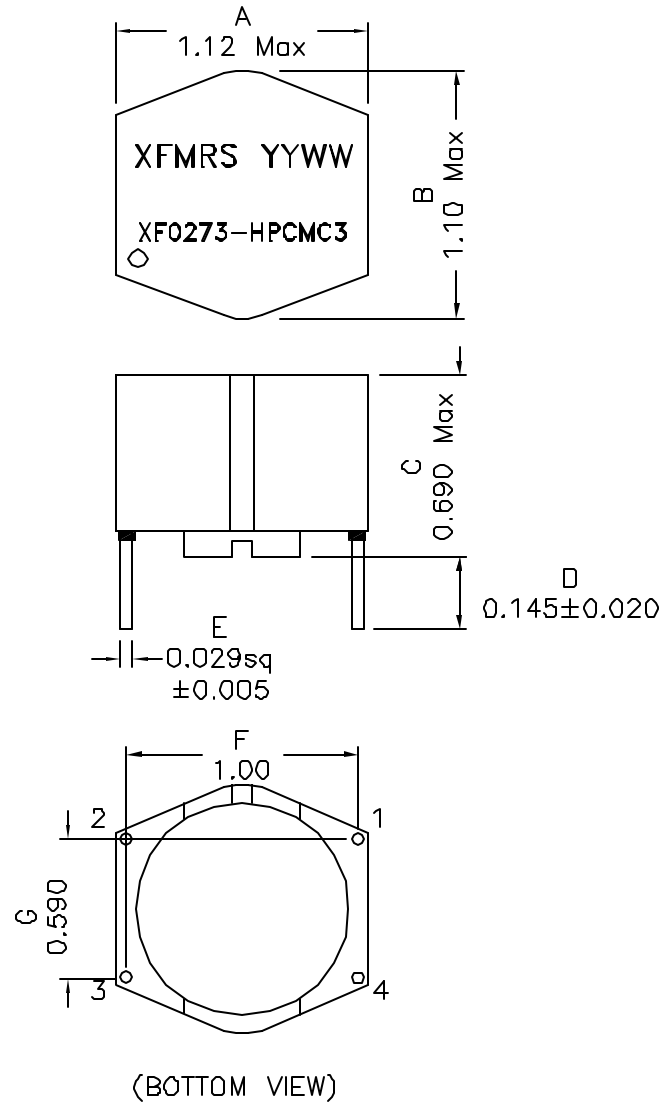

2. Schematic:

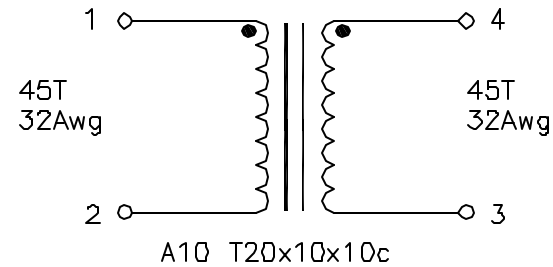

3. Electrical Specifications: @25°C

OCL: 27mH±30% @10KHz 0.05V Each Wdg.

DCR: 750 mOhms Typ, Each Wdg.

LL: Pins 1-2 440uH Typ @100KHz, 0.1V (Short Pins 4-3)

Rated Current: 1A

Isolation Voltage: 1500Vac, Wdg. to Wdg., 2 Sec

Rated Voltage: 250Vac

Notes:

1. Solderability: Leads shall meet MIL-STD-202G, Method 208H for solderability.
2. Flammability: UL94V-0
3. ASTM oxygen index: > 28%
4. Insulation System: Class F 155°C, UL file E151558
5. Operating Temperature Range: All listed parameters are to be within tolerance from -40°C to +85°C
6. Storage Temperature Range: -55°C to +125°C
7. Aqueous wash compatible
8. Electrical and mechanical specifications 100% tested
9. RoHS Compliant Component

XFMRS Inc. www.XFMRS.com	Title: Common Mode Choke		
	P/N: XF0273-HPCMC3		REV. A
UNLESS OTHERWISE SPECIFIED TOLERANCES: .xxx ±0.020	DWN.	李小锋	Nov-01-06
	CHK.	廖玉坤	Nov-01-06
Dimensions in INCH	APP.	MS	Nov-01-06
SHEET 1 OF 1			

DOC. REV A/3