

1. Mechanical Dimensions:

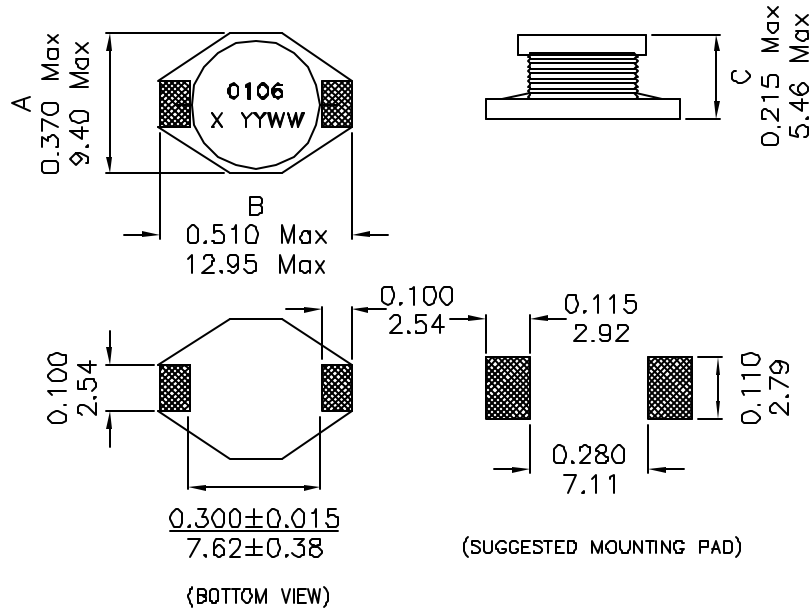

2. Schematic:



3. Electrical Specifications: @25°C

INDUCTANCE: 10uH ± 20% @ 100KHz 0.1V

Q: 10 Min @ 100KHz 0.1V

ISAT: 3.8Adc Inductance drop by 10% typ

Irms: 3.9A for 40°C rise

SRF: 30MHz Typical

DC RESISTANCE: 0.038 OHMS Maximum

Notes:

1. Solderability: Leads shall meet MIL-STD-202G, Method 208H for solderability.
2. Flammability: UL94V-0
3. ASTM oxygen index: > 28%
4. Insulation System: Class F 155°C. UL file E151556
5. Operating Temperature Range: All listed parameters are to be within tolerance from -40°C to +85°C
6. Storage Temperature Range: -55°C to +125°C
7. Aqueous wash compatible
8. SMD Lead Coplanarity: ±0.004" (0.102mm)
9. Electrical and mechanical specifications 100% tested
10. RoHS Compliant Component
11. 260°C Reflow Compatible

DOC. REV. B/8

| | | | |
|--|---------------|-----------------------------------|-----------|
| XFMRs Inc. www.XFMRS.com | | Title: XFMSD1 SERIES INDUCTORS | |
| UNLESS OTHERWISE SPECIFIED TOLERANCES: .xxx ±0.010 INCH Dimensions in INCH/MM | P/N: XF0106S1 | | REV. B |
| | DWN. | Feng | Mar-26-11 |
| | CHK. | YK Liao | Mar-26-11 |
| SHEET 1 OF 1 | APP. | Joe Huff | Mar-26-11 |