

1. Mechanical Dimensions:

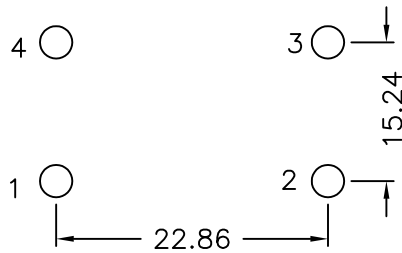

SUGGESTED FOOTPRINT

2. Schematic:

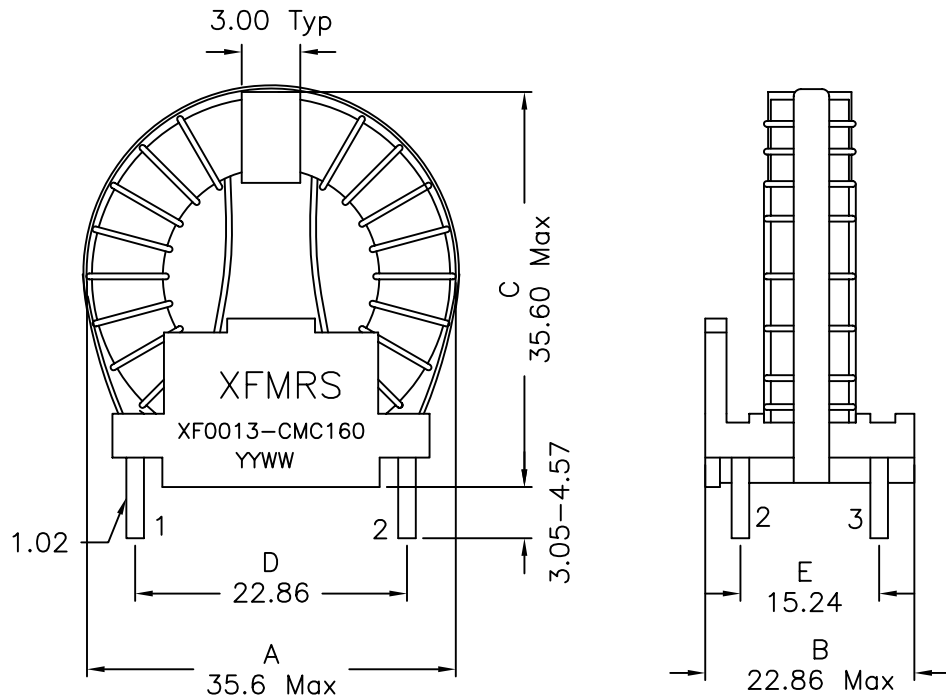
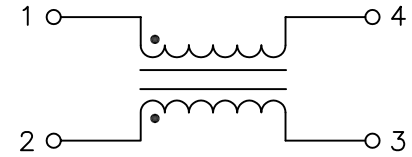

3. Electrical Specifications: @25°C

- OCL: 1.1mH Min @1KHz 0.1V, Each Wdg, 0°C to +85°C
- 0.55mH Min @1KHz 0.1V, Each Wdg, -40°C to 0°C
- Q: 80 Min @1KHz 0.1V, Each Wdg
- DCR: 0.020 Ohms Max, Each Wdg
- LL: Pins 1-4 20uH Min 100KHz 0.1V, Short Pins 2-3
- SRF: 900KHz Typical
- Current Rating: 8.1Amps
- ISOLATION: 1250Vac, Wdg to Wdg

Notes:

1. Solderability: Leads shall meet MIL-STD-202G, Method 208H for solderability.
2. Flammability: UL94V-0
3. ASTM oxygen index: > 28%
4. Insulation System: Class F 155°C. UL file E151556
5. All listed parameters are to be within tolerance from -40°C to +85°C unless otherwise noted
6. Storage Temperature Range: -55°C to +125°C
7. Aqueous wash compatible
8. Electrical and mechanical specifications 100% tested
9. RoHS Compliant Component

DOC REV.: A/5

XFMRS Inc www.XFMRS.com	Title: Common Mode Choke		
	UNLESS OTHERWISE SPECIFIED	P/N: XF0013-CMC160	REV. A
TOLERANCES: .xx ±0.20	DWN.	Feng	Apr-11-11
Dimensions in mm	CHK.	YK Liao	Apr-11-11
SHEET 1 OF 2	APP.	BW	Apr-11-11

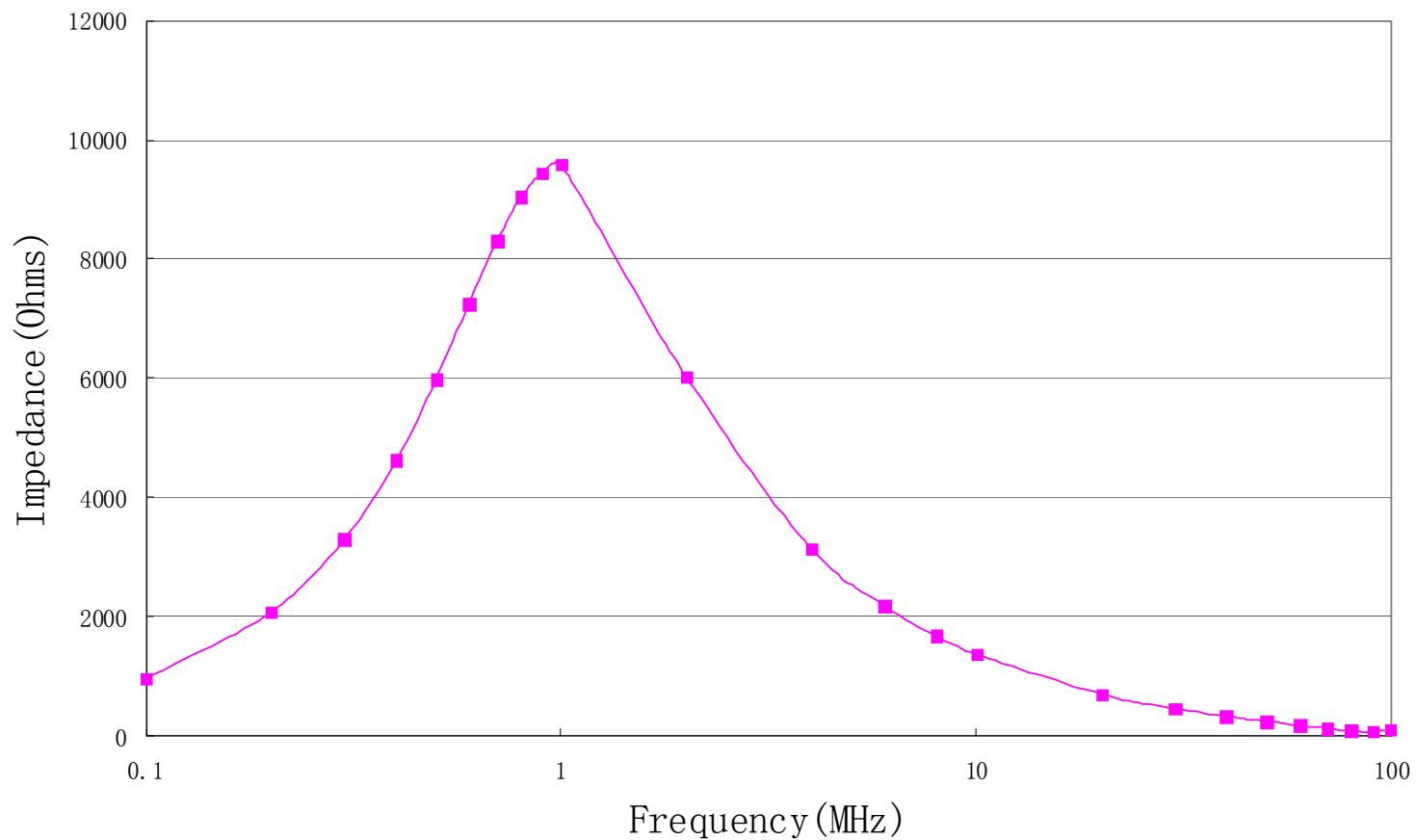

DOC REV.: A/5

XFMRs Inc www.XFMRS.com	Title: Common Mode Choke			
	UNLESS OTHERWISE SPECIFIED TOLERANCES: .xx ±0.20 Dimensions in mm		P/N: XF0013-CMC160	REV. A
SHEET 2 OF 2	DWN.	Feng	Apr-11-11	
	CHK.	YK Liao	Apr-11-11	
	APP.	BW	Apr-11-11	

PROPRIETARY

Document is the property of XFMRs Group & is not allowed to be duplicated without authorization.